



ASABE International Quarter-Scale Tractor Student Design Competition

2022 Rules and Regulations

Table of Contents

1 Overview	3
2 General Configuration	3
3 Frame	4
4 Operator's Station	5
5 Steering	5
6 Engine	6
7 Transmissions, Clutches and Driveline	9
8 Tires	13
9 Fenders	13
10 Shielding	14
11 Hitch Area and Wheelie Bars	17
12 Ballast	21
13 Sound	21
14 Electrical Components	22
15 Data Acquisition	23
16 Miscellaneous	24

1 Overview

- 1.1 These rules are intended to provide the official requirements for a vehicle to be entered in the ASABE Quarter Scale Vehicle Student Design Competition.
- 1.2 Some or all of points in this document may be checked for conformance during the technical inspections.
- 1.3 The rules dated for the current year's competition are to be considered the A-team rules.
- 1.4 The rules dated for the 2021 year's competition are to be considered the X-team rules.
- 1.5 For all questions about the rules please contact the Competition Rules Chair
 - 1.5.1 Chance Corum, CorumChanceM@JohnDeere.com
- 1.6 The rules chair and rules committee have final judgement on any interpretations or questions which may or may not be covered in this document.

2 General Configuration

- 2.1 For the purposes of this document, the term 'fully ballasted' means the vehicle is ballasted to 1600 lbs. (725 kg), including the operator.
- 2.2 All vehicles are required to have a fully charged, dry 2-lb. fire extinguisher (BC rating with functional gauge)
 - 2.2.1 It must be mounted securely to the vehicle at all times.
 - 2.2.2 It must be easily accessible and remain in its original mount and location throughout the event
- 2.3 The vehicle must meet the following size and weight constraints
 - 2.3.1 Maximum width of 72 inches (1829 mm)
 - 2.3.2 Maximum length of 122 inches (3099 mm) forward of the centerline of the rear axle
 - 2.3.3 Maximum weight of 900 lbs. (408 kg) maximum gross vehicle weight
 - 2.3.3.1 Including all fluids but excluding operator and ballast.
- 2.4 Unless otherwise noted in a specific rule, the vehicle must remain in the same configuration as was required to pass technical inspections for all scored events, including judging.
 - 2.4.1 The exhaust system and any sound attenuating features used during the technical inspections must also remain in the same configuration during the entire competition with no addition, adjustment, or removal of any components or accessories during any part of the competition.
- 2.5 If a component fails, the team must show the designated competition official that the failed component was replaced with a comparable component.
- 2.6 Vehicles must meet the minimum approach and departure angles as depicted in Figure 1 below.
 - 2.6.1 This includes weights and mid-body chassis clearance while driving on and off the scales or brake test stand.

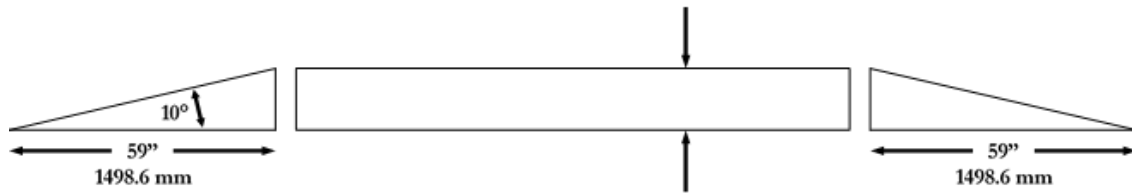

Figure 1 - Approach and Departure Angle Requirements

- 2.7 For the durability event, vehicles must meet a minimum 6-inches (152-mm) ground clearance for the length of the vehicle, with exception of the side to side projected area between the tires for each axle.
- 2.8 Any air or fluid suspension system must be used in accordance with the specifications of the manufacturer.
- 2.9 Vehicles must include a tow hook with a minimum 1.25-inch (32mm) hole on the front of the vehicle.
 - 2.9.1 It must be rigid enough to tow fully ballasted vehicle and provide clearance for attaching a tow rope.
- 2.10 Wheelbase changes are not allowed unless they can be accomplished by the driver from the seat.
- 2.11 Any fastening hardware that is required to meet a specific grade must have standard head markings as indicated in Figure 2.
 - 2.11.1 Socket head fasteners with a black oxide coating are assumed to be Grade 8.

SAE Grade 2		Metric Grade 5.8	
SAE Grade 5		Metric Grade 8.8	
SAE Grade 8		Metric Grade 10.9	

Figure 2 - Standard Hardware Grade Markings

- 2.12 Operator safety must be considered in the design and layout of all controls and components. Reference ISO 3411 and/or ISO 26322 to ensure that vehicle designs safeguard the operator from injury due to contact with any components including tires during normal operation and during conditions of instability (wheel hop, front-end rear-ups, etc.). Designs must ensure that no part of the operator can contact exhaust pipe(s) when leaning forward or back.

3 Frame

- 3.1 Each team must design a fully customized frame.
 - 3.1.1 Commercially available lawn and garden vehicle chassis or frames are NOT allowed in any form, segmented, modified, reproduced, or otherwise.

4 Operator's Station

- 4.1 Operator presence and drivetrain disconnect detection devices are required to prevent inadvertent cranking and or starting of the engine and/or unintended machine motion.
 - 4.1.1 An operator presence device must be used and must not allow cranking of the engine unless the operator is in the operator's position, in the seat.
 - 4.1.2 A drivetrain disconnect detection device must be used and must not allow cranking of the engine unless the drivetrain is validated to be disconnected.
 - 4.1.3 With the engine running and the drivetrain placed in neutral, the machine must remain stationary without operator input.
- 4.2 The seat and support must be adequate to maintain the operator's weight without any major deflection or failure during safe operation of vehicle. The seat must meet the following requirements:
 - 4.2.1 Minimum backrest height of 12-inches (305 mm)
 - 4.2.2 Maximum seat base depth of 22 inches (559 mm)
 - 4.2.3 Maximum seat base width of 20 inches (508 mm)
 - 4.2.4 Maximum of 36 inches (915mm) from top of seat pan to ground level
 - 4.2.5 Must not 'flip-up' during operation of the vehicle
 - 4.2.6 The back of the seat must not extend beyond the back of the rear tires.
 - 4.2.7 Must not be a plain pan-type seat
 - 4.2.8 Must not be adjusted during operation of the vehicle
- 4.3 Seats must include functional armrests on both sides. The armrests must meet the following requirements:
 - 4.3.1 Be rigid in the fore/aft, lateral, and downward directions during operation.
 - 4.3.2 Extend a minimum of 8-inches (203 mm) from the front surface of the seat back
 - 4.3.3 Be positioned a minimum of 6-inches (152 mm) above the top surface of the seat base.
- 4.4 Vehicles equipped with a drive by wire type set up (i.e. no steering wheel), must incorporate a grab handle and it must be positioned so that the driver can use it as support when operating the vehicle.
- 4.5 Vehicles must include operator footrests; they must be sturdy and rigidly mounted to the vehicle frame/chassis.
 - 4.5.1 They must protect the operator from inadvertent contact with all tires and the ground.

5 Steering

- 5.1 No rear or mid wheel steering.
- 5.2 All steering system components must use retaining nuts which must be castle or locking nuts (nylon or thread deforming) with a minimum of 2 threads showing.
 - 5.2.1 If a screw is used in a threaded hole it must have a spring lock washer.
- 5.3 Note that hydraulic system requirements may also be applicable; consult hydraulic section.
- 5.4 All steering tires must partially track within at least two of the rear tires when the vehicle is driven straight forward.

- 5.5 Minimum front tire track width must be 24 inches (610 mm) on center.
- 5.6 Skid Steer Type Steering
 - 5.6.1 Controls must utilize a deadman type control such that if the control is released wheel motion ceases.
 - 5.6.2 Control must be locked out unless the operator is in the operator's position, in the seat.
- 5.7 Articulated Type Steering
 - 5.7.1 An articulation lock is to be incorporated into the design of the steering system. It must meet the following requirements:
 - 5.7.1.1 Locks the machine in the centered position.
 - 5.7.1.2 Is capable of withstanding full steering force.
 - 5.7.1.3 Must be easily installed, without tools.
 - 5.7.1.4 Must be retained on the vehicle at all times.
 - 5.7.2 Control must be locked out unless the operator is in the operator's position, in the seat.

6 Engine

General

- 6.1 All vehicles must use a single Briggs & Stratton 31-hp Vanguard engine (Models 543477-0110-E1, 543477-0157-E1, 543477-1110-E1, 543477-3110-B1, or 543477-3110-G1) factory sealed as delivered. No unauthorized modifications or repairs, internal or external, will be allowed to the engine except as specified in this section.
- 6.2 Only Briggs and Stratton accessories can be installed on the engine, except for exhaust systems.
 - 6.2.1 The use of any such accessory must be approved via the Rules Chair.
 - 6.2.2 Teams are responsible for the purchase of accessories.
- 6.3 Turbo-chargers, superchargers or other forced induction systems are not permitted.
- 6.4 Engine/engine shroud must maintain the original manufacturer's color scheme and may not be altered in any manner.
- 6.5 The original engine flywheel must remain intact and may not be altered in any manner.
- 6.6 Gasoline will be supplied at the competition to ensure equal engine performance. Eighty-seven (87) octane fuel will be used.
- 6.7 Any oil brand that satisfies Briggs & Stratton operator manual recommendations is acceptable.
- 6.8 Combustible additives/compounds or any other performance enhancing additive may not be added to the fuel, lubrication, or air intake systems.
- 6.9 Original factory installed ignition system may not be altered in any manner. However, teams are permitted to substitute factory-installed spark plugs with any brand of choice.
- 6.10 The 8-pin electrical connector on the 31-hp engine must remain as installed from the factory. Part numbers for the mating connector are as follows:
 - 6.10.1 Housing – Packard/Pioneer p/n 2965972
 - 6.10.2 Terminals – Packard/Pioneer p/n 2965481
 - 6.10.3 One complete set of these mating connector parts will be shipped with each 31-hp engine

Disconnects

- 6.11 A positive powertrain disconnect must be incorporated and must be located between the engine PTO and the drivetrain.
 - 6.11.1 This positive disconnect may be a sliding coupler, Lovejoy coupler, Dodge coupler, or bare shaft
- 6.12 Vehicles must not have bearings installed on either front or rear engine PTO shafts i.e. no bearing can rotate when engine is disconnected from drivetrain.
- 6.13 Any component remaining on the engine shaft may not exceed 4 inches (102 mm) in diameter and must be completely free to rotate with the engine shaft (i.e. may not be connected to a fixed member of the vehicle).
- 6.14 Disengaged clutches are not considered an acceptable disconnect.
- 6.15 Components left on the engine shaft during engine tech inspections must be shielded as required in normal operation (i.e., shields removed to aid in disconnecting the powertrain must be replaced).
- 6.16 Each engine must be able to be disconnected in less than 2 minutes by one person and reconnected in less than 2 minutes by one person.
 - 6.16.1 This includes the removal and installation of any shields, guards, and/or body components; exhaust heat shields may not be removed.

Governor and Throttle

- 6.17 Each 31-hp engine is equipped with a governor that is factory set to 3600 rpm “top no-load speed”.
- 6.18 The idle for the 31-hp engine will be set to either 1550 rpm (spring 809863) or 1750 rpm (spring 809875) during the tech inspection (teams can choose either based on their idle spring).
- 6.19 Random inspection of the governor may be conducted at any time during the competition. Tampering with any part of the governor mechanism may result in disqualification.
 - 6.19.1 Teams are responsible to ensure that their engine is set to – and remains set to – the appropriate speeds.
- 6.20 Adequate clearance must be provided to install and use the Briggs and Stratton speed adjusting tool.
 - 6.20.1 Figure 3 shows the locations of the high and low idle adjustments for the 31-hp engine.
- 6.21 The carburetor must remain stock as delivered. Jets and needles may not be replaced, and all stock adjusters must be used.
- 6.22 The vehicle must have a “Dead-man” throttle, which returns the engine to low idle upon release.
- 6.23 The throttle return spring must not be attached to or within 12 inches (305 mm) of the sliding component of the engine control bracket, see Figure 3.
- 6.24 The engine throttle control at the operator station must move the throttle sliding component through its full range of travel (from stop to stop).

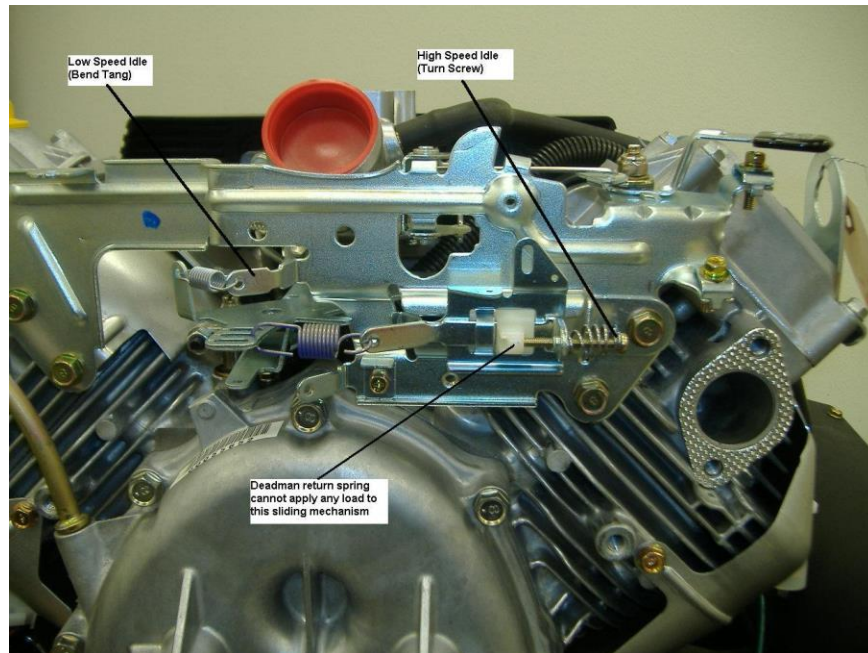

Figure 3 - Throttle and Governor Adjustment Details

Fuel System

- 6.25 Fuel pumps must only be used in their factory delivered form and must meet the requirements as listed.
 - 6.25.1 Maximum pump inlet pressure of 1.5-psi (10.3-kPa)
 - 6.25.2 Teams are not allowed to remove the stock fuel pump or modify any lines connected to it, other than the suction line. If more head pressure is needed prior to the original fuel pump, an additional fuel pump can be used to do this, provided it does not exceed 1.5 psi (10.3 kPa).
 - 6.25.3 Electric fuel pumps, if used, must disable when the kill switch is activated
 - 6.25.4 Additional impulse vacuum pumps are not permitted
- 6.26 The fuel filter must be within the specified maximum hose length from the factory installed fuel pump inlet.
 - 6.26.1 31-hp Engine Models 0110-E1 and 0157-E1 – 20 inches (508 mm)
 - 6.26.2 31-hp Engine Models 1110-E1, 3110-B1, and 3110-G1 – 7.5 inches (191 mm)
- 6.27 One fuel tank per vehicle is permitted and must meet the following requirements:
 - 6.27.1 Maximum capacity of 6 quarts (5.68 L)
 - 6.27.2 Incorporate a 1-quart level mark via a sight gauge on opaque tanks or a marking on the tank for transparent tanks
 - 6.27.3 A manual fuel supply shutoff must be incorporated and must meet the following requirements:
 - 6.27.3.1 Be installed between the tank and the fuel pump
 - 6.27.3.2 Be easily accessible from the outside of the vehicle and without removal of vehicle components

- 6.27.4 A dedicated drain line must be incorporated and must meet the following requirements:
 - 6.27.4.1 Include a control valve
 - 6.27.4.2 Be easily accessible from outside the vehicle and without removal of vehicle components
 - 6.27.4.3 Must drain to the ground without contacting any other vehicle components.
- 6.28 Fuel tank must be mounted a minimum of 24-inches (610mm) from the battery.
 - 6.28.1 It must not be mounted in the same sealed compartment as any battery.
- 6.29 Fuel tank must have a minimum opening of 1.25 inches (32 mm) diameter and be equipped with a vented cap.
- 6.30 Access to refuel the vehicle with the Briggs and Stratton Smart-Fil fuel can must be provided.
- 6.31 If a fuel cooling system is utilized, it may not contain nitrogen or other harmful chemicals.

Exhaust System

- 6.32 Exhaust systems must be guarded per ISO 5395-3 Section 4.12, with the exception that hoods may not be used as guards. Guards should be constructed of high-quality materials, so they do not deflect under reasonable load and contact any exhaust component.
- 6.33 Exhaust pipes and exhaust gases must be positioned and directed such that they will not affect the vehicle operator, track personnel and/or sled operator. In addition, exhaust discharge may not be pointed downward or within 45 degrees to the rear of the vehicle.

7 Transmissions, Clutches and Driveline

General Requirements

- 7.1 All clutch assemblies must rotate at engine speed or slower.
- 7.2 With the engine running and the drivetrain placed in neutral, the machine must remain stationary without operator input.
- 7.3 No energy storing devices may be used to power the transmission.
 - 7.3.1 A clutch assembly will NOT be considered an energy-storing device, if it is reasonably designed.
- 7.4 The vehicle drivetrain must have the same configuration for all performance and scored events. Only components related to drivetrain ratio changes are allowed to be switched. (i.e. teams will not be allowed to swap a locked differential for an unlocked one or vice versa. Teams may not swap complete drive axles.)

Hydraulics

- 7.5 The maximum system working pressure allowed for hydraulic systems on a vehicle is 4,000 + 50 psi (276 + 3.4 bar).
 - 7.5.1 Maximum pressure must be controlled by a relief valve, and
 - 7.5.1.1 It must be set equal to or less than the lowest intermittent pressure rating of any component in the system.
 - 7.5.2 Non-powered brake and steering system are exempt.
- 7.6 Hydraulic hoses, tubes, and fittings must be rated for the corresponding system working pressure.

- 7.6.1 Hoses must be clearly marked with the OEM working pressure rating.
- 7.7 Pipe thread fittings are only allowed on pump suction lines, tank sight gages, or OEM components (i.e. hydraulic cylinder, hand powered steering pump, etc.).
 - 7.7.1 The hydraulic line attached to the OEM component port may ONLY utilize a pipe thread fitting to make the connection at the OEM component, unless the connection at the other end meets the exceptions defined by this rule.
 - 7.7.2 Note: OEM (Original Equipment Manufacturer) components are defined as components sourced from another completed product (a direct component supplier is not an OEM).
 - 7.7.2.1 For an OEM component with pipe thread fittings to be accepted for use at competition, documentation from the equipment manufacturer must be provided for the component to show it is rated for the working pressure of the vehicle's hydraulic system. This documentation must be submitted with the documentation required in rule 7.13.
- 7.8 Hose clamps are only acceptable on pump suction lines and tank sight gages.
- 7.9 Components, regardless of system pressure, may not be welded or braised with the exception of pump suction lines or a reservoir.
- 7.10 A method for checking the system pressures must also be considered. The vehicle must meet the following requirements.
 - 7.10.1 Non-powered brake and steering system are exempt
 - 7.10.2 An easily accessible test port, meeting SAE J1502, must be present at the high-pressure side of the pump in each separate circuit.
 - 7.10.3 The vehicle must provide a means (i.e. needle valves, solenoid valves, etc.) for all system pressures to be tested without having to install external hardware into the systems during technical inspection.
 - 7.10.4 All test ports and components necessary for the pressure checking must remain on the vehicle at all times.
- 7.11 Hydraulic lines must be located and routed robustly and must meet the following requirements:
 - 7.11.1 ALL exposed hoses during normal operation must be completely covered with a protective hose covering or continuous shielding.
 - 7.11.2 Are not subject to damage from debris or from installing or removing adjacent components
 - 7.11.3 Prevent operator contact when mounting or dismounting the operator station.
 - 7.11.4 Must not rub any sharp edges or are properly guarded where damage may result.
 - 7.11.5 Have a mechanism (clip/clamp intended for hydraulic use) to guide multiple hoses through their range of motion to prevent fouling (rubbing) or abrasive action.
- 7.12 Fasteners for hydraulic lines must be designed to withstand the line movement caused by pressure fluctuations in the system.
- 7.13 If a hydraulic system is used on the vehicle, some additional pre-competition requirements are to be met. The team must provide the following to the rules chair by the last Friday in March:
 - 7.13.1 Hydraulic system schematic
 - 7.13.1.1 The schematic must include system components (tank, pumps, valves, motors, relief valves, check valves, test ports, etc.) drawn with standard symbols (refer to ISO 1219), as well as specifications pertaining to those components that dictate system operating characteristics (relief valve

setting, flow from a pump, check valve ratings, orifice diameters, pump speed ratio, etc.). See example in Figure 4, below.

- 7.13.2 Component list with factory specified pressure ratings, see example in Figure 4, below.
- 7.13.3 If not received by the above stated date, the team will not be eligible for "First Time Through" award for tech inspections.
- 7.13.4 Any changes after the due date must be submitted to the person named above, immediately. Unpowered hydraulic steering systems do not require this documentation.

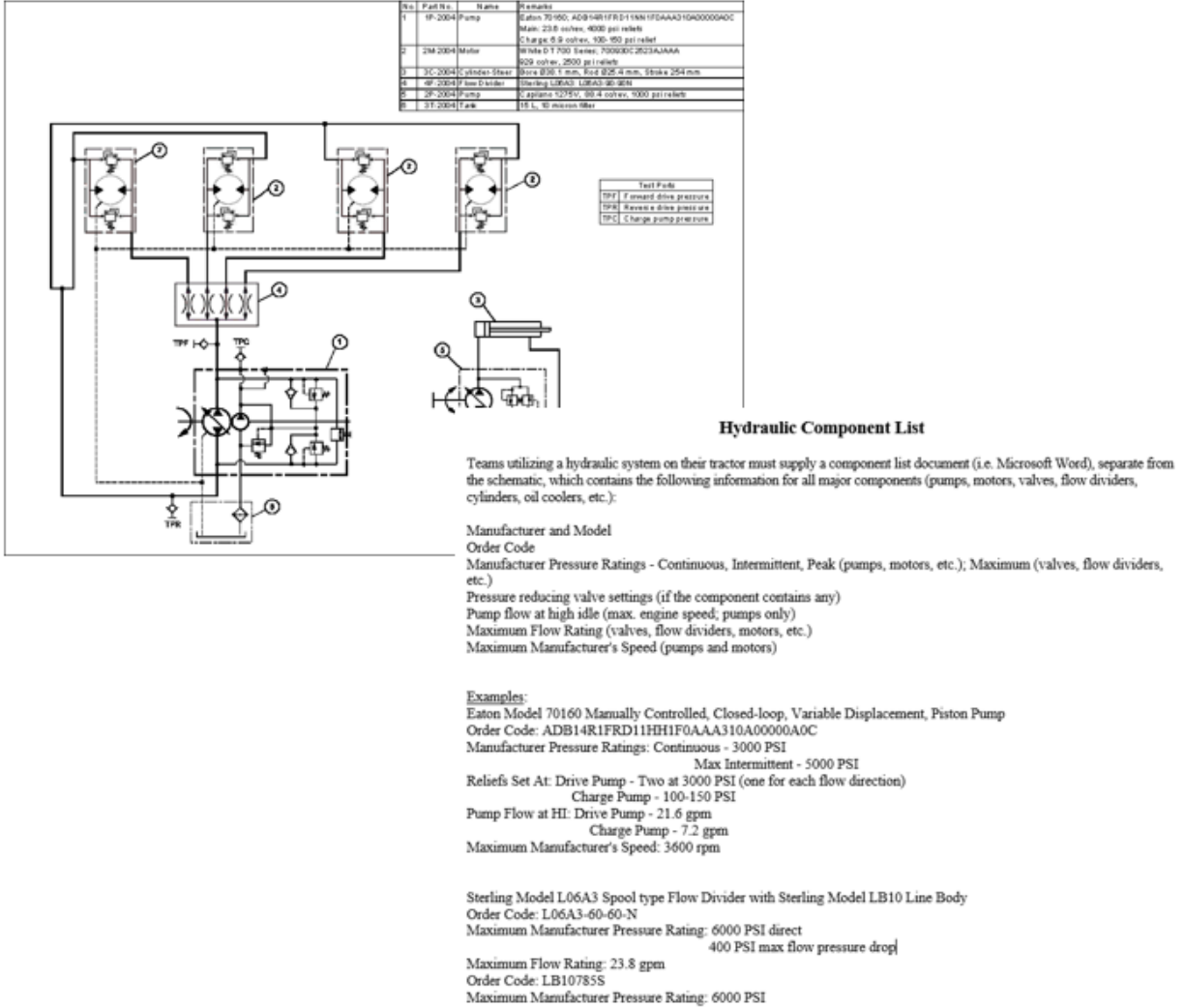

Figure 4 - Hydraulic Schematic and Component List Examples

Electric Drivetrains

- 7.14 All connections are to be made with voltage and amperage appropriate connectors
- 7.15 All connections must be covered with a voltage and amperage appropriate cover
- 7.16 All circuits must contain adequate circuit protection in the form of a breaker or fuse
- 7.17 All circuits carrying potential above battery voltage must be sheathed with high visibility orange covering.
- 7.18 A lamp must be incorporated which is illuminated whenever circuits carrying potential above battery voltage are energized.
 - 7.18.1 This lamp must be part of the circuit itself.
- 7.19 Vehicle must contain a method/procedure to reach a zero-energy state.

Other Mechanical Transmissions

- 7.20 Variable belt drive transmissions are not allowed to change drive ratios by means of flyweights or a torque sensing helix.

Brakes

- 7.21 Vehicles must have working service brakes.
- 7.22 The service brakes must be capable of fully locking the tires, with the vehicle fully ballasted, on an incline of 20° without sliding.
- 7.23 A dynamic brake will NOT be allowed unless it is in conjunction with working service brake(s).

8 Tires

- 8.1 Vehicles must use a minimum of 2 Titan 26 x 12.00-12 TRU POWER tires as drive tires and must meet the following requirements:
 - 8.1.1 Remain uncut for the purposes for technical inspections.
 - 8.1.2 Be mounted on a wheel (rim) no wider than 12 inches (305mm)
 - 8.1.3 Sidewalls must remain unaltered for all events
- 8.2 Any other drive tire must be smaller in diameter than the Titan 26 X 12.00-12 TRU POWER tire.
 - 8.2.1 These must be mounted on a wheel (rim) in accordance with the manufacturer's requirements
- 8.3 The same number of drive tires must be used throughout the competition.
- 8.4 Tires may be conditioned, cut, or sharpened for all performance events
- 8.5 Tires may not be recapped.
- 8.6 Tires are the only approved traction device.

9 Fenders

- 9.1 Fenders must be functional, sturdy, and rigidly mounted to protect the driver from any wheels that the operator can contact from the operator's station during operation. The fenders must meet the following requirements:
 - 9.1.1 Cover at least two-thirds the width of all affected tires
 - 9.1.2 Include inner fender walls to protect the operator from inadvertent contact with tires.
 - 9.1.3 Minimum radial coverage of 90 degrees and positioned so they best protect the operator.
 - 9.1.4 Deflect less than 0.5-inches (12.7 mm) towards the tire at the outermost edge when a 5-lb (2.27-kg) weight is placed on the fender over the centerline of the outermost tire.
 - 9.1.5 Minimum clearance of 1.2 inches (30 mm) between the component and tire/rim peripheral area
 - 9.1.6 Minimum clearance of 0.6 inches (15 mm) between the component and the inside of the tire.

10 **Shielding**

- 10.1 ASABE, SAE, ANSI, ISO, and OPEI have developed numerous safety and shielding standards for agricultural equipment.
 - 10.1.1 Minimum shielding requirements must meet or exceed ASAE Standard S493, "Guarding for Agricultural Equipment." Specific shielding requirements are shown in the remainder of this section:
- 10.2 The hood may not be used as a shield or as a guard.
- 10.3 Engine shields that are stock for the engine must remain intact, including the flywheel rotating screen.
 - 10.3.1 If the flywheel screen is the furthest point forward on the vehicle, a bumper must be incorporated to prevent contact between the rotating screen and stationary objects encountered during vehicle movement (i.e. posts or other objects during vehicle maneuvering in tight areas).
- 10.4 All shields must be securely fastened to the vehicle frame or associated chassis members.

Operator Shielding

- 10.5 All parts moving parts of the vehicle that the operator can come into contact with while stationary, during normal starting and during operation must be enclosed or guarded to prevent entanglement, pinching or other dangers.
 - 10.5.1 The material type and thickness is open, as long as it prevents inadvertent contact from the hazard.
 - 10.5.2 No specific fastener is required.

Rotating Driveline Components

- 10.6 Shielding must cover rotating drivetrain parts, excluding bare shafts but including couplers; shielding must be: See Figure 5, below.
 - 10.6.1 Peripheral area: Minimum 1/8-inch (3 mm) thick for low carbon steel, or 0.25-inch (6 mm) thick for aluminum.
 - 10.6.2 Sides: May use expanded metal, provided it meets or exceeds ASAE Standard S493
 - 10.6.3 Couplers beyond final drive reduction are excluded.

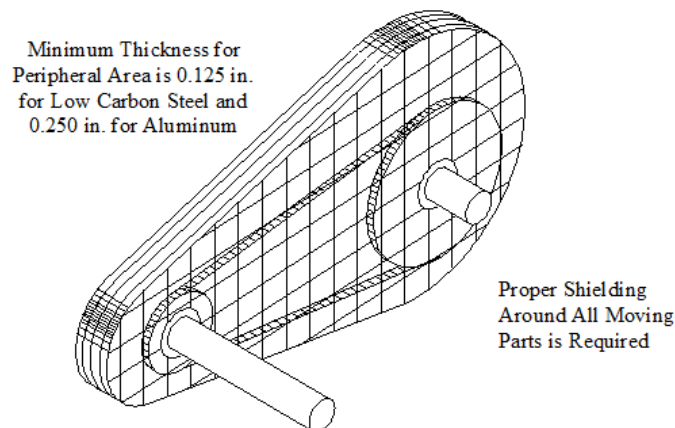

Figure 5 - Clutch Shielding Example

10.7 Regardless of use, variable belt drive transmissions must be shielded as clutches.

10.8 Belts operating as a clutch must be shielded as a clutch.

Clutches

10.9 Shielding must cover clutches and must be:

10.9.1 Fully enclosed, any openings should adhere to 10.9.5

10.9.2 Minimum of 1/8-inch (3 mm) thick low carbon steel or 0.25 inch (6 mm) thick aluminum.

10.9.3 Utilize bolts or capscrews of at least 0.25-inch (6-mm) in diameter.

10.9.4 Tools must be required to remove the shielding.

10.9.5 Openings will be allowed for venting or passing through of other components if they meet the following requirements:

10.9.5.1 No more than 6 total openings.

10.9.5.2 Not on the peripheral area of the clutch.

10.9.5.3 Openings adjacent to the peripheral area of a clutch must be no closer than 1.5 in (38.1mm) from an edge of the peripheral area of the clutch.

10.9.5.4 There is a maximum of 1/4" (6.35mm) opening in shielding for venting and/or between the shield and the component passing through the shield (i.e. chain, belt, etc.).

10.9.5.5 Deflectors exist to prevent material that could come through the openings from contacting the operator or bystanders (i.e. frame rails, footrests, etc.).

Driveshaft Loops

10.10 Driveshafts, regardless of length, must include safety loop(s) to secure the driveshaft if a component were to break or loosen during operation. The loop(s) must meet the following requirements.

10.10.1 Be situated such that they equally divide the length of the driveshaft within a tolerance of 2-inches (50-mm).

10.10.2 Maximum distance between loops is 18-inches (457-mm)

10.10.3 Be fabricated from steel or aluminum.

10.10.4 Driveshafts beyond final drive reduction are excluded.

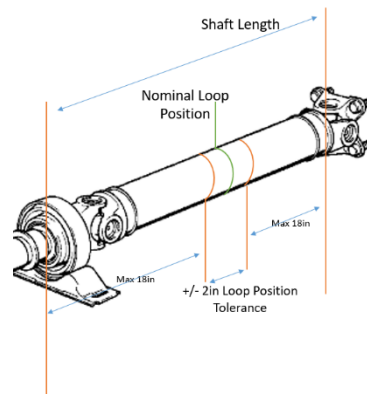

Figure 6 - Driveshaft Loop Detail

OEM Shielding

10.11 Vehicle designs can use original equipment stock shielding for components if the manufacturer designed the shield for the specified component for the intended application. Teams are required to contact manufacturers and discuss proposed application, mounting arrangement, and ASABE rule specifications.

10.11.1 Teams must supply the manufacturer with appropriate design specifications/drawings and documentation to make sure shield is adequate and receive written authorization to use the shield in the vehicle design.

10.12 Shield must be properly mounted/installed and may not be modified (i.e. drilling holes to lighten) in any manner that would weaken the original design

10.13 Teams must submit written manufacturing authorization for OEM shields by the last Friday in March.

10.13.1 This documentation must be submitted to the rules chair. The shield will not be allowed at the competition if it is not submitted.

10.13.2 Note: Documentation will not be accepted after the deadline.

10.13.3 Manufacturer literature or specifications must also be presented to technical inspection judges to verify shielding meets competition rules.

11 Hitch Area and Wheelie Bars

11.1 Vehicle hitch, frame components, ballast, or any other vehicle components may not contact, support, or interfere with the hook or chain or trailer tongue at any time during the performance events.

Kill Switch

11.2 All vehicles must have two working kill-switches that shut off the ignition and electric fuel pump (if one is installed) in the event of the vehicle becoming detached from the sled, as shown in Figure 7, below.

11.2.1 One kill switch must incorporate a 0.5-inch (13 mm) hole to which a tether cord can hook. The switch is activated when the tether cord is pulled.

11.2.2 The other kill switch must utilize the connector prescribed by section 14.4. The switch is activated when a ground signal is applied to the specified pin.

11.3 The kills switches must both be in the same area defined by the requirements below:

11.3.1 Within 3 inches (75mm) of centered side to side on the vehicle

11.3.2 Be positioned 13 - 15 inches (330 - 381 mm) above the vehicle hitch/hook point of the sled chain.

11.3.3 A 5-inch (127 mm) square opening around each of the kill switches is required to allow for unobstructed hookup of the tether and mating connector.

11.3.4 Kill switches must be rigidly mounted in all directions.

11.3.5 This opening must remain unobstructed when the vehicle is fully ballasted.

11.4 Kill switches may not be mounted to the hitch. Mounting hardware must be independent of the hitch such that the kill switch will remain intact in the event of hitch failure.

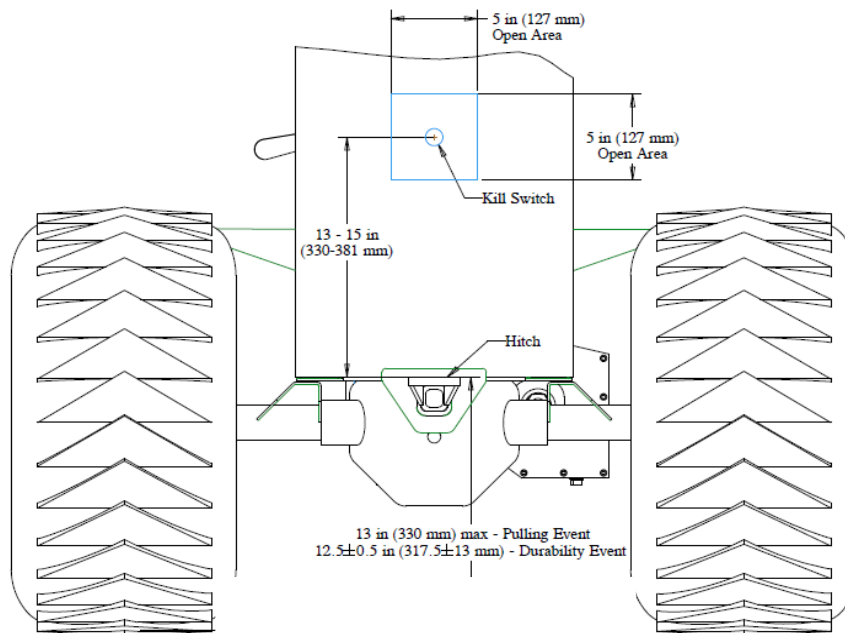

Wheelie Bars

- 11.5 All vehicles must have two wheelie bars and two bumper-bars and must meet the following requirements:
 - 11.5.1 Wheelie bar designs can use either wheels or pads.
 - 11.5.2 Minimum distance of 5 inches (127 mm) between the center of the wheel or pad the rear of rear tires
 - 11.5.3 For the pulling events, the bottom of the wheel or pad may not be higher than 4 inches (102 mm) above the ground.
 - 11.5.4 For the durability event, the bottom of the wheel or pad must be a minimum of 6-inches (150-mm) and a maximum of 8 inches (200 mm) above the ground.
 - 11.5.5 If pads are used, minimum effective area of 18 total square inches (116 cm²) or no less than 9 square inches (58 cm²) per pad.
 - 11.5.6 If wheels are used, minimum effective diameter of 4 inches (102 mm) and a minimum effective width of 2 inches (51 mm) per wheel.
- 11.6 Wheelie bars must be rigid in all directions
 - 11.6.1 When supported by one wheel/pad, they must be capable of supporting the machine fully ballasted, with operator, without deformation or significant deflection.

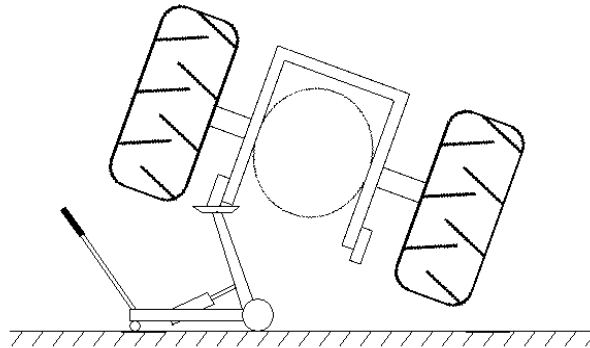

Figure 8 - Wheelie Bar Structural Test Setup

- 11.7 Bumper-bars must protect wheelie pads/wheels from inadvertent sled contact. The bumper bars must meet the following requirements:
 - 11.7.1 Be the furthest point rearward on the vehicle.
 - 11.7.2 Be rigidly attached to the back of the wheelie bars
 - 11.7.3 Consist of a 6-inch (152 mm) vertical member that will prevent the sled from “riding up” the wheelie bars.
 - 11.7.4 Must be individual bars on each wheelie bar.
- 11.8 During durability events only, the bumper bar(s) may be placed in a stowed position to prevent interference with the load cart’s tongue.
 - 11.8.1 In the stowed position, the bumper bar(s) must remain attached to the wheelie bar structure.

Hitch

- 11.9 Vehicles will be allowed a maximum hitch height of 13 inches (330 mm) for the pulling event. For the durability event, the hitch height must be 12.5 +/- 0.5 inches (317.5 +/- 13 mm)
- 11.10 All hitch height measurements will be made against the highest portion of hooking point, relative to the ground.
- 11.11 Active suspension systems must be able to reach its extremes on the scales for hitch height checks prior to each pull.
- 11.12 A hitch must be incorporated into the rear of each vehicle and it must meet the following requirements:
 - 11.12.1 Be attached to the vehicle frame or axle and be structurally independent from the wheelie bars
 - 11.12.2 Be on or rearward of the centerline of the rear axle.
 - 11.12.3 Have a means to lock rigidly in all directions
 - 11.12.4 Not move relative to the vehicle chassis once locked
 - 11.12.5 Be fabricated from low carbon steel plate having a thickness of ½ to ¾-inch (13 to 19 mm).
 - 11.12.6 Incorporate a 1 7/8 +/- 1/8 inch (47 +/- 3 mm) diameter hole.
 - 11.12.7 Pulling point may not be more than ¾-inch (19 mm) from back edge of hitching device
 - 11.12.8 Threaded fasteners, if used, must be a minimum of SAE Grade 5 or Metric Grade M8.8 throughout the entire hitch and for its connection to the frame or axle.
 - 11.12.8.1 Retaining nuts, if used, must be locking-nuts (nylon or thread deforming) with a minimum of two threads showing above the nut.
- 11.13 Hook point must allow for easy hooking and unhooking of the chain and have clearance zones meeting the requirements as indicated in Figure 9 and Figure 10, below.
 - 11.13.1 These clearances must be maintained when the vehicle is fully ballasted.

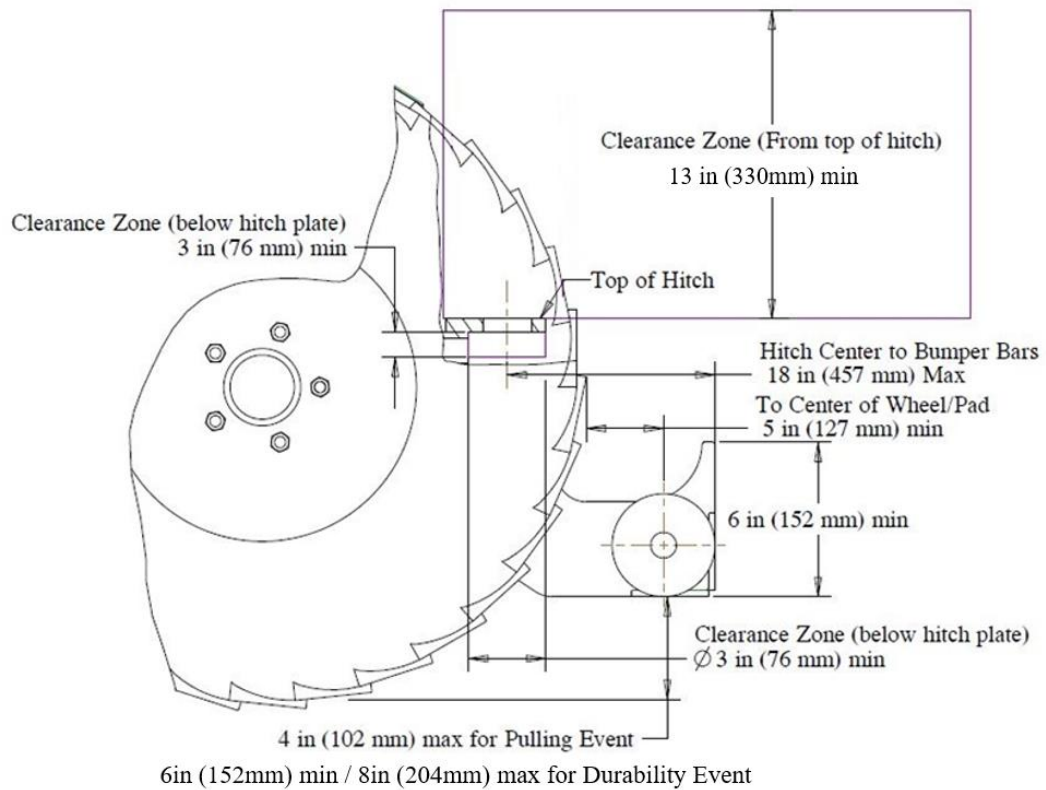

Figure 9 - Wheelie Bar and Hitch Detail A

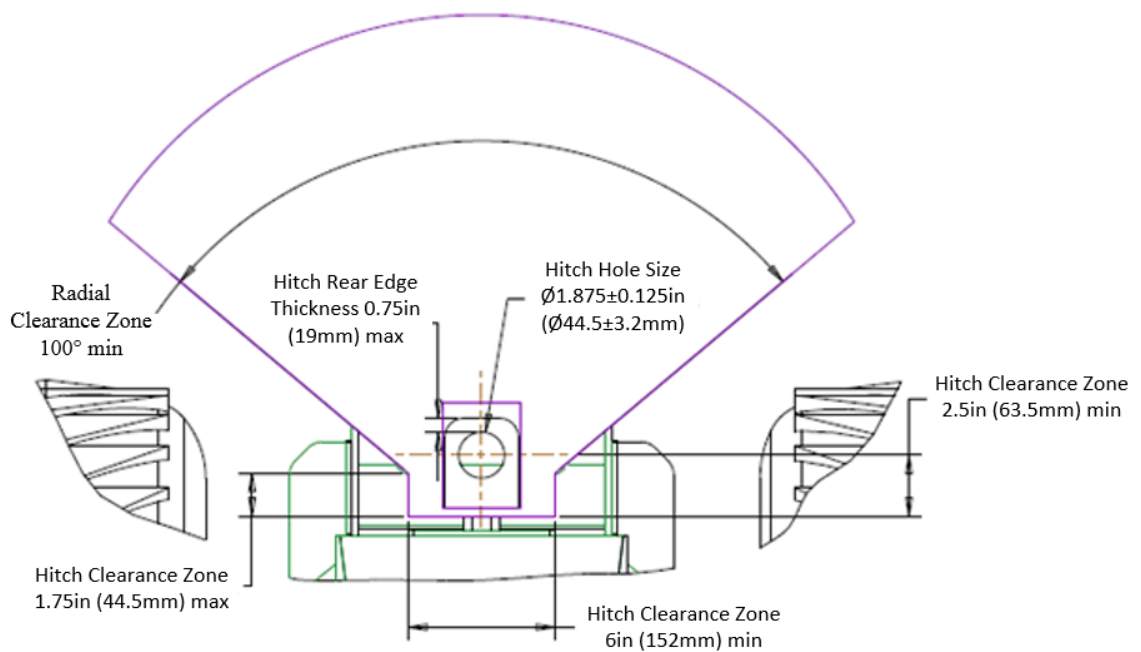

Figure 10 - Wheelie Bar and Hitch Detail B

12 Ballast

- 12.1 Ballast is an object whose sole purpose is to be used to balance the vehicle.
 - 12.1.1 Examples of ballast include weights, driver, and weight brackets.
 - 12.1.2 Examples of non-ballast items include hoods, front axles, body components, and drivetrain components.
- 12.2 Only ballast can be added and removed between pulls.
- 12.3 The rear weights must not protrude more than 6 inches (152 mm) past the rear-most point of the rear tires.

13 Sound

- 13.1 The maximum pass-by noise level with the engine at full throttle and a forward ground speed of 4 ± 2 mph may not exceed 94 dB(A).
 - 13.1.1 Sound measurements will be taken at a distance of 4.0 m (13.1 ft) from the centerline of a 20 m driving path, with the microphone located vertically at 1.2 m (3.9 ft).
 - 13.1.2 The maximum level will be taken as the Fast Max, A-Weighted sound pressure level at the microphone during the time that the vehicle is in the test range.
 - 13.1.3 Three runs will be made in each direction, and the final level will be the higher of the average of the two directions.
- 13.2 Vehicles must have a means to maintain required ground speed at full engine speed without the use of clutch shims, riding the clutch, etc.

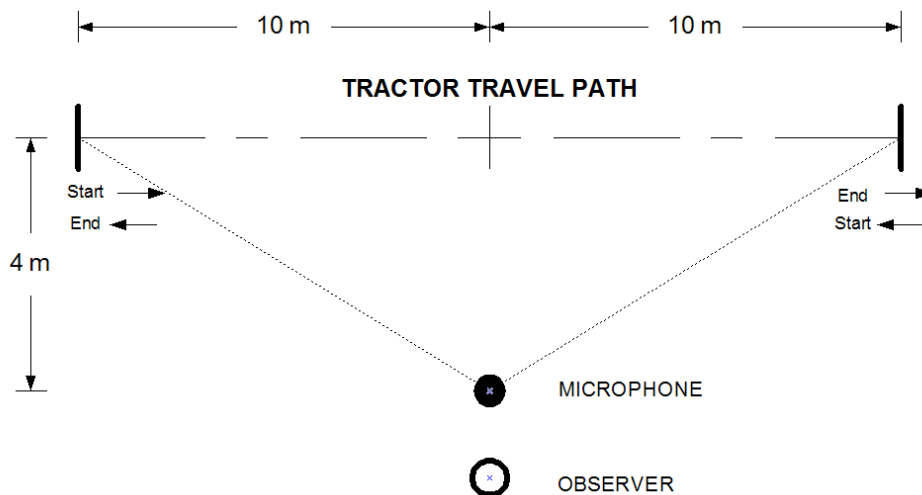

Figure 11 - Sound Test Layout

14 Electrical Components

14.1 All positive terminals throughout the machine must be completely covered to avoid inadvertent contact.

Battery

14.2 Vehicle designs are limited to a single battery.

14.2.1 Battery must be capable of starting the vehicle consistently.

14.2.2 Vehicles will not be allowed to have "jump start" once hooked to the sled or during any scored event.

14.2.3 Manufacturer label with specifications must be intact.

14.3 Battery must be rigidly mounted on the vehicle frame/chassis in a well-ventilated compartment. (The use of rubber or elastic straps to secure batteries will not be permitted)

Interface Connector

14.4 Each vehicle must incorporate the connector in figure 12. The connector shall meet the following requirements:

14.4.1 Wired according to table 1 .

14.4.1.1 Should a team desire to use the CANbus connection during competition, the vehicle must contain two, 120ohm, terminating resistors.

14.4.2 Located and operate in accordance with 11.2, 11.3 and 11.4

14.4.3 Dust cap must be included and installed when not in use

14.4.4 Functionally equivalent connectors, accessories and contacts are acceptable; connector housing must be aluminum

Connector:	HD34-18-14SE
Connector Manufacturer:	TE Connectivity
Contacts (Non-Sensitive Circuits)	0462-201-16141
Contacts (Sensitive Circuits)	0462-201-1631
Dust Cap	HDC36-18



Figure 12: Interface Connector Details

A	+12v Unswitched Power (5A)	Required	Non-Sensitive
B	Battery Ground (5A)	Required	Non-Sensitive
C	Kill Switch Signal	Required	Non-Sensitive
D	CAN_H (twisted w CAN_L)	Optional	Sensitive
E	CAN_L (twisted w CAN_H)	Optional	Sensitive

Table 1: Connector Pinout

15 Data Acquisition

- 15.1 Data acquisition and controllers are allowed in the vehicle design but may not affect or alter any portion of the engine performance.
- 15.2 Power for sensors or data acquisition devices may be supplied by a separate battery source.
 - 15.2.1 Only data acquisition devices may utilize this separate battery source.

16 Miscellaneous

Controllability

16.1 All vehicles are required to pass a controllability test, which demonstrates the machine’s ability to safely start, stop, and change direction in tight spaces. Vehicles must be fully ballasted for the duration of this test. The test is considered a pass if the procedure below is followed within the controllability area.

16.1.1 Test Procedure:

- 16.1.1.1 With the engine running and the drivetrain placed in neutral, the machine must remain stationary without operator input.
- 16.1.1.2 Enter controllability area – vehicles may enter from either end of the test area.
- 16.1.1.3 Place a single rear tire fully within the boundary of the rectangle opposite the end of the entrance and bring vehicle to a complete stop. (Note: once the selected rear tire has entered the first rectangle, that rear tire may not leave the 56 x 24 in. area of the two rectangles until the test is complete)
- 16.1.1.4 The rear tire must remain within the first rectangle for a minimum of 10 seconds (with the vehicle engine running).
- 16.1.1.5 Place the same single rear tire fully within the boundary of the second rectangle and come to a complete stop.
- 16.1.1.6 The rear tire must remain within the second rectangle for a minimum of 10 seconds (with the vehicle engine running).
- 16.1.1.7 With the engine running and the drivetrain placed in neutral, the machine must remain stationary without operator input.

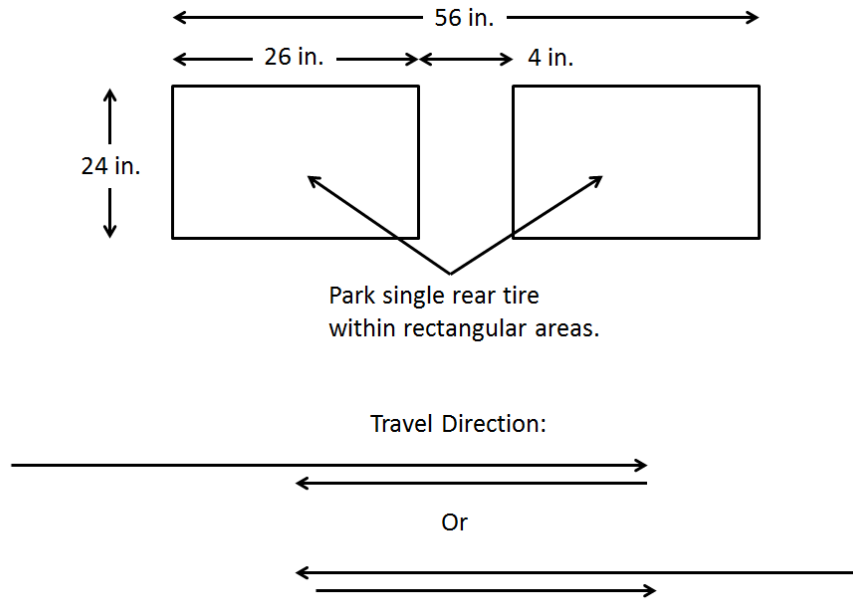

Figure 13 - Controllability Test Layout

Decals and Labelling

- 16.2 All teams must display the logo of the competition, major sponsors and their school's name and number on at least three sides of the vehicle.
 - 16.2.1 Sponsor decals will be supplied at the event and must be used.
 - 16.2.2 The team name must be legible and printed in letters that are at least 2 inches tall; an abbreviation or acronym is acceptable.
 - 16.2.3 The team number must be legible and printed in numbers that are at least 4 inches tall.
 - 16.2.4 All decals must be in place in order to complete technical inspection.
 - 16.2.5 Sponsor decals must not be modified or trimmed in any way.
- 16.3 Teams are responsible for making sure that all logos are displayed during all pulls. Failure to comply may result in team disqualification.
- 16.4 Specific decal sizes and quantities will be listed in the Competition Handbook or other ASABE mailing.